

S m a r t S t a n d s™

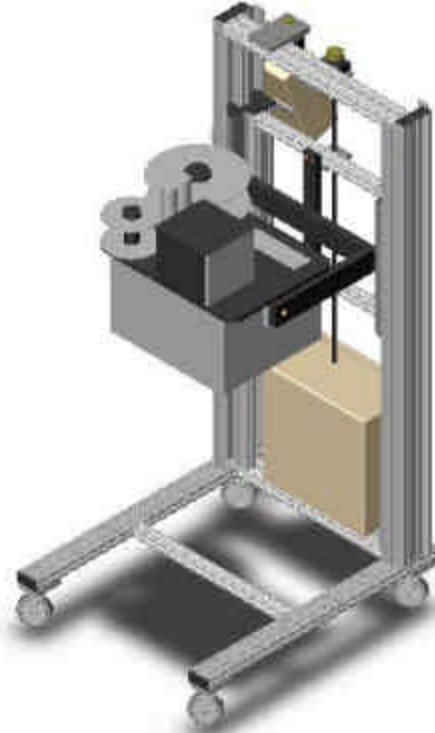

Shown with label applicator

- ☛ *Use in conjunction with automatic labeling and inkjet systems*
- ☛ *Programmable for your specific labeling needs*



Shown with operator interface

The Hadley Smart Stands allow label applicators and inkjets to be positioned automatically based on the selected product. With a couple of screen selections the coding units will move to their pre-assigned positions. Even the individual applicator product sensors when mounted to the Hadley Vertical Carton Feeder move to their assigned positions! We are very excited to offer this product which is an exclusive to the Hadley labeling equipment family. It truly fulfills the expression "Just Load and Code"!

Standard Features

- ☛ Aluminum framework
- ☛ Mounted casters
- ☛ User defined positions

S m a r t S t a n d s TM

System Specifications

O P T I O N S

- ☞ Expanded Memory
- ☞ Horizontal Version

Dimensions

30"L x 36"W x 70"H

Maximum Carton Size

N/A

Thickness Range

N/A

Printing/Labeling Productivity

N/A

Power Input

120VAC (240VAC optional)

Air Requirements

None

Construction

Industrial-grade aluminum, mounted on casters for easy movement

Corporate Headquarters

14412 N. Lincoln Blvd
Edmond, Ok 73013 U.S.A.
Toll Free: 1.TOOL.INKJET
Phone: 405.409.7695
Fax: 866.426.3066
E-Mail: sales@hadleydesign.com
www.hadleydesign.com